

## Modular Cooking Range Line thermaline 90 - Gas French Top on Static Gas Oven, 1 Side, H=700

ITEM # \_\_\_\_\_

MODEL # \_\_\_\_\_

NAME # \_\_\_\_\_

SIS # \_\_\_\_\_

AIA # \_\_\_\_\_

**589637 (MCVGEAJCPO)**

 Gas French Top on gas  
 static Oven, one-side  
 operated

### Short Form Specification

#### Item No.

Unit constructed according to DIN 18860\_2 with 20 mm drop nose top and 70 mm recessed plinth. Internal frame for heavy duty sturdiness in stainless steel. 2 mm top in 1.4301 (AISI 304). Flat surface construction, easily cleanable. THERMODUL connection system enables seamless worktop when units are connected and avoids soil penetrating. Large surface cooking plate made with durable cast iron, allows the use of various sizes of pans. Central gas burner with optimized combustion, flame failure device and protected pilot light. Center of the plate can reach max. 550°C while decreasing outwards, thus allowing temperature gradients to satisfy different cooking needs. Electrical ignition powered by battery with thermocouple for added safety. Safety thermostat and thermostatic control. Metal knobs and oven handles with embedded hygienic silicon "soft" grip enable easier handling and cleaning.

Gas static oven chamber with 40 mm thick oven door and ribbed enamelled steel base plate. Oven chamber with 2 levels of runners for 2/1 GN shelves to enable simultaneous and faster cooking. Heavy duty thermostat with temperature range up to 300°C, electronic sensor for precise temperature control and manual humidity control in the cooking chamber. Upper heating element can also be used for grilling, with or without ventilating mode. IPX4 water resistant certification.

Configuration: Freestanding, One-side operated.

### Main Features

- Durable cast iron cooking plate, easy to clean.
- Central burner with optimized combustion, flame failure device and protected pilot light.
- Oven temperature up to 300 °C
- Pans can easily be moved from one area to another without lifting.
- Safety thermostat and thermostatic control.
- Various sizes of pans can be used at the same time due to large surface area with no intermediate sectors.
- 40 mm thick oven door for heat insulation.
- THERMODUL connection system creates a seamless work top when units are connected to each other thus avoiding soil penetrating vital components and facilitating the removal of units in case of replacement or service.
- Metal knobs with embedded hygienic "soft-touch" grip for easier handling and cleaning. The special design of the controls prevents infiltration of liquids or soil into vital components.
- Oven chamber to have 2 levels of runners to accommodate 2/1 GN trays and ribbed enamelled steel base plate.
- The upper heating element of the oven can also be used for grilling.
- Manual control of humidity in cooking chamber.
- Electronic sensor for precise temperature control.
- Electrical ignition powered by battery with thermocouple for added safety.
- 100% safety pilot and thermocouple.
- Manual oven shut-off valve.
- All major components may be easily accessed from the front.
- Large visible digital display manufactured in tempered glass to resist heat and chemicals, showing temperatures or power settings. The display also shows on/off status of the appliance and on/off status of the heating elements.
- The center of the plate can reach a maximum temperature of 550 °C while decreasing outwards.

### Construction

- 2 mm top in 1.4301 (AISI 304).
- Unit constructed according to DIN 18860\_2 with 20 mm drop nose top and 70 mm recessed plinth.
- Flat surface construction with minimal hidden areas to easily clean all surfaces
- IPx4 water protection.

APPROVAL: \_\_\_\_\_



**Electrolux**  
PROFESSIONAL

**Modular Cooking Range Line  
thermaline 90 - Gas French Top on  
Static Gas Oven, 1 Side, H=700**

- Internal frame for heavy duty sturdiness in stainless steel.



**Modular Cooking Range Line  
thermaline 90 - Gas French Top on Static Gas Oven, 1 Side, H=700**  
The company reserves the right to make modifications to the products  
without prior notice. All information correct at time of printing.

2026.04.14

### Included Accessories

- 1 of Grid, chromium plated, for ovens 2/1 GN PNC 910652

### Optional Accessories

- Baking sheet 2/1 GN for ovens PNC 910651
- Bottom steel plate 2/1 GN for fire clay plate 800&900 with baking oven PNC 910655
- Fire clay plate 2/1 GN for ovens PNC 910656
- Connecting rail kit, 900mm PNC 912502
- Stainless steel side panel, 900x700mm, freestanding PNC 912512
- Portioning shelf, 1000mm width PNC 912528
- Portioning shelf, 1000mm width PNC 912558
- Folding shelf, 300x900mm PNC 912581
- Folding shelf, 400x900mm PNC 912582
- Fixed side shelf, 200x900mm PNC 912589
- Fixed side shelf, 300x900mm PNC 912590
- Fixed side shelf, 400x900mm PNC 912591
- Stainless steel front kicking strip, 1000mm width PNC 912636
- Stainless steel side kicking strip left and right, freestanding, 900mm width PNC 912657
- Stainless steel side kicking strip left and right, back-to-back, 1810mm width PNC 912663
- Stainless steel plinth, freestanding, 1000mm width PNC 912960
- Connecting rail kit: modular 90 (on the left) to ProThermetic tilting (on the right), ProThermetic stationary (on the left) to ProThermetic tilting (on the right) PNC 912975
- Connecting rail kit: modular 80 (on the right) to ProThermetic tilting (on the left), ProThermetic stationary (on the right) to ProThermetic tilting (on the left) PNC 912976
- Endrail kit, flush-fitting, left PNC 913111
- Endrail kit, flush-fitting, right PNC 913112
- Endrail kit (12.5mm) for thermaline 90 units, left PNC 913202
- Endrail kit (12.5mm) for thermaline 90 units, right PNC 913203
- Stainless steel side panel, left, H=700 PNC 913222
- Stainless steel side panel, right, H=700 PNC 913223
- T-connection rail for back-to-back installations without backsplash (to be ordered as S-code) PNC 913227
- Insert profile d=900 PNC 913232
- Endrail kit, (12.5mm), for back-to-back installation, left PNC 913251
- Endrail kit, (12.5mm), for back-to-back installation, right PNC 913252
- Endrail kit, flush-fitting, for back-to-back installation, left PNC 913255
- Endrail kit, flush-fitting, for back-to-back installation, right PNC 913256
- Side reinforced panel only in combination with side shelf, for freestanding units PNC 913260
- Side reinforced panel only in combination with side shelf, for back-to-back installations, left PNC 913275

- Side reinforced panel only in combination with side shelf, for back-to-back installation, right PNC 913276
- Stainless steel dividing panel, 900x700mm, (it should only be used between Electrolux Professional thermaline Modular 90 and thermaline C90) PNC 913672
- Stainless steel side panel, 900x700mm, flush-fitting (it should only be used against the wall, against a niche and in between Electrolux Professional thermaline and ProThermetic appliances and external appliances - provided that these have at least the same dimensions) PNC 913688

Front

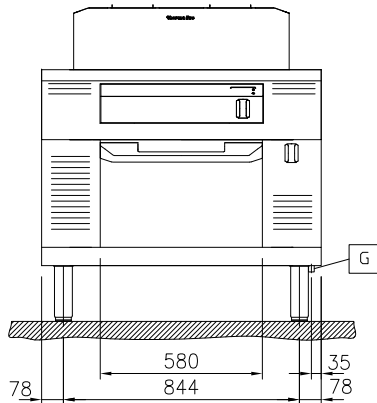

Side

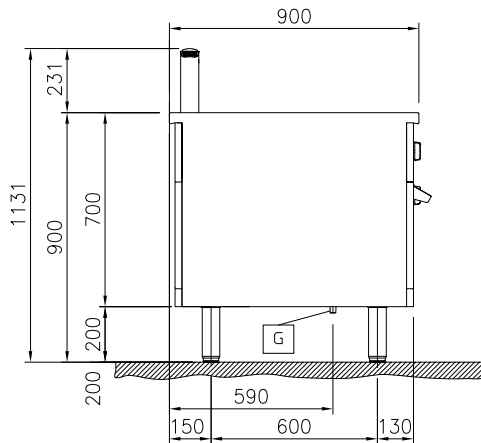

EQ = Equipotential screw  
 G = Gas connection

Top

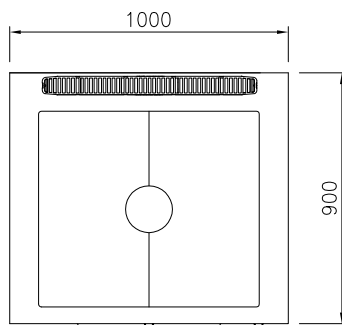

### Gas

Gas Power:	19.5 kW
Gas Type Option:	
Gas Inlet:	1/2"

### Key Information:

Oven working Temperature:	80 °C MIN; 300 °C MAX
Oven Cavity Dimensions (width):	683 mm
Oven Cavity Dimensions (height):	255 mm
Oven Cavity Dimensions (depth):	671 mm
External dimensions, Width:	1000 mm
External dimensions, Depth:	900 mm
External dimensions, Height:	700 mm
Net weight:	195 kg
Configuration:	On Oven; One-Side Operated
Oven GN:	GN 2/1
Solid top usable surface (width):	790 mm
Solid top usable surface (depth):	700 mm